



H E A T I N G

## Light oil burner

Vectron® L 1.40/42/55/95

Vectron® Eco 1.34/50/75

Vectron® BLUE 1.20/24/28/30/35/47



Class 3



Class 2

elco

# Vectron® 1



## Eco-friendly

### Protecting the environment

As part of our commitment to sustainable development, at elco we are constantly innovating to develop our technology with the environment in mind. This is why the new Vectron® 1 oil burner incorporates clean combustion with improved performance

- Low NOx class 2 emitting 185 mg NOx/kWh,
- class 3 variant emitting 120 mg NOx/kWh,
- burner and packaging 100% recyclable,
- reduced consumption of electricity.



## Intelligent

### For permanent communication of information which is easy to use

With its new MDE2® System and the integrated display, the Vectron® 1 oil burner provides constant information updates for professionals and users. Instantaneous data (starting cycle, voltage measurement values and flame signal, etc.) and stored data (operating statistics) are now displayed.



- Immediate access to MDE2® System operating data
  - > display integrated on each burner,
  - > Elcogram® universal language
- User services
  - > light oil level indicator,
  - > maintenance interval indicator makes maintenance easy to manage.

### Elcogram®, a universal language

As elco products are distributed worldwide, the company has developed a universal language composed of pictograms and numerical data. The pictograms use the majority of the symbols used on the wiring diagrams which are recognised and understood by all Nations. This ensures that information is quicker and easier to read, than ever before.



# Silent

For optimal acoustic comfort

Relating directly to the user's day-to-day comfort, the acoustics on the Vectron® 1.40/42/55 oil burner have been designed to ensure optimal well-being. The sound level has therefore been lowered by 4 decibels compared with the previous unit and is now only 64 dB(A), which means that the sound level is half of what it was.

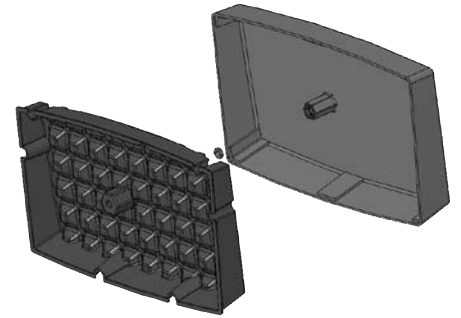

- air intake box made from composite materials, equipped with a honeycomb structure which works like a sound trap,
- polymer seal between the volute and the plate, which guarantee an optimal seal against pressurised air,
- polypropylene cover, which reduces air noise.

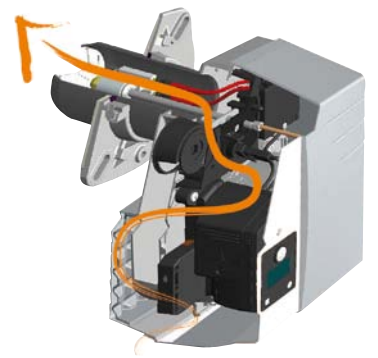

# Stylish

A dynamic and functional design

The grey Vectron® 1 light oil burner can easily be integrated into any boiler. The control panel's vertical white stripe makes it easy to identify.



- robust, angular and cube-shaped
- harmonious colours for optimal integration
- control panel with a display which is easy to read without removing the cover.

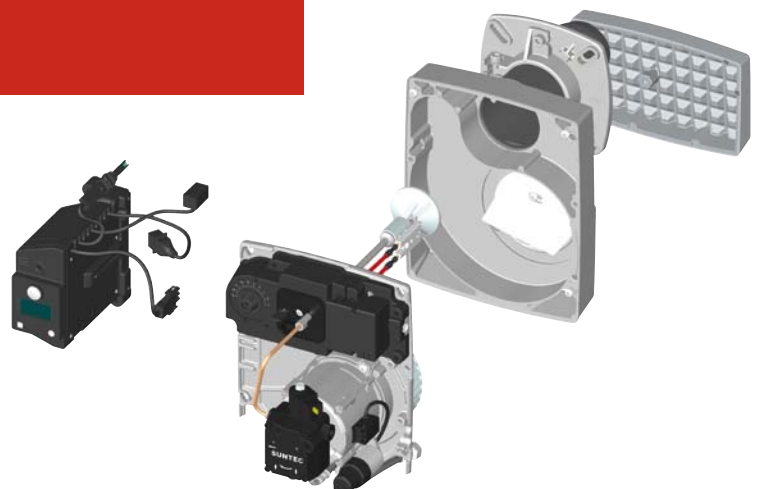

# Technical characteristics

## Working fields

VL 1.40 P

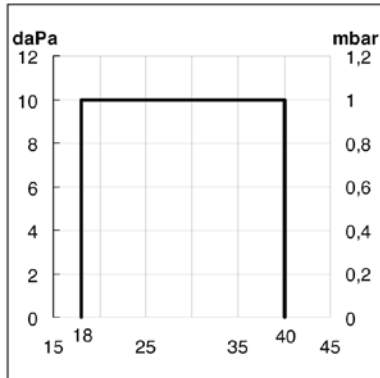

VL 1.42, VL 1.55/55P

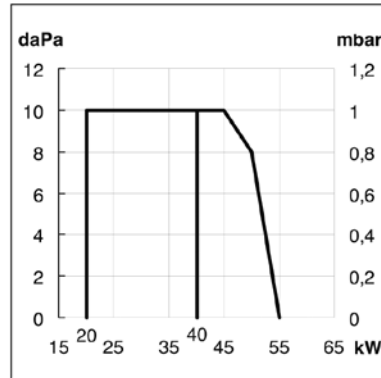

VL 1.95

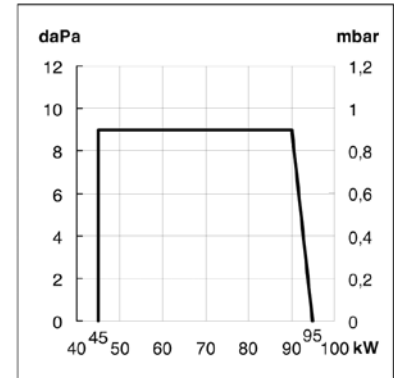

## Overall dimensions

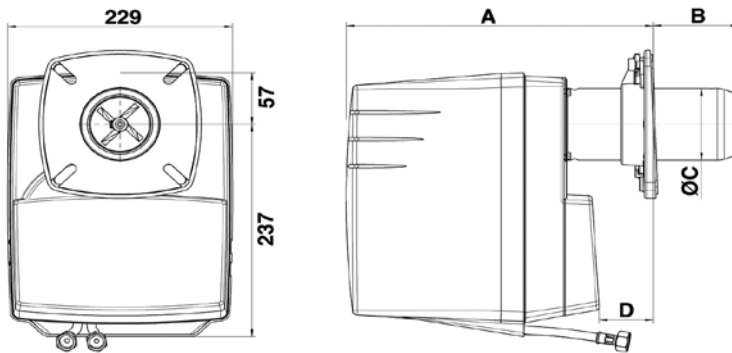

	A (mm)		B (mm)		ØC (mm)	D (mm)	
	min. (*)	max.	min. (*)	max.		min. (*)	max.
VL 1.40, VL 1.40P	270	310	70	120	80	21	71
VL 1.42	270	310	70	120	80	21	71
VL 1.55, VL 1.55P	270	310	70	120	80	21	71
VL 1.95	297	357	70	138	90	15	83

DEALER STAMP